

LX memory controller

128MB or 256MB DDR DRAM (PC400)

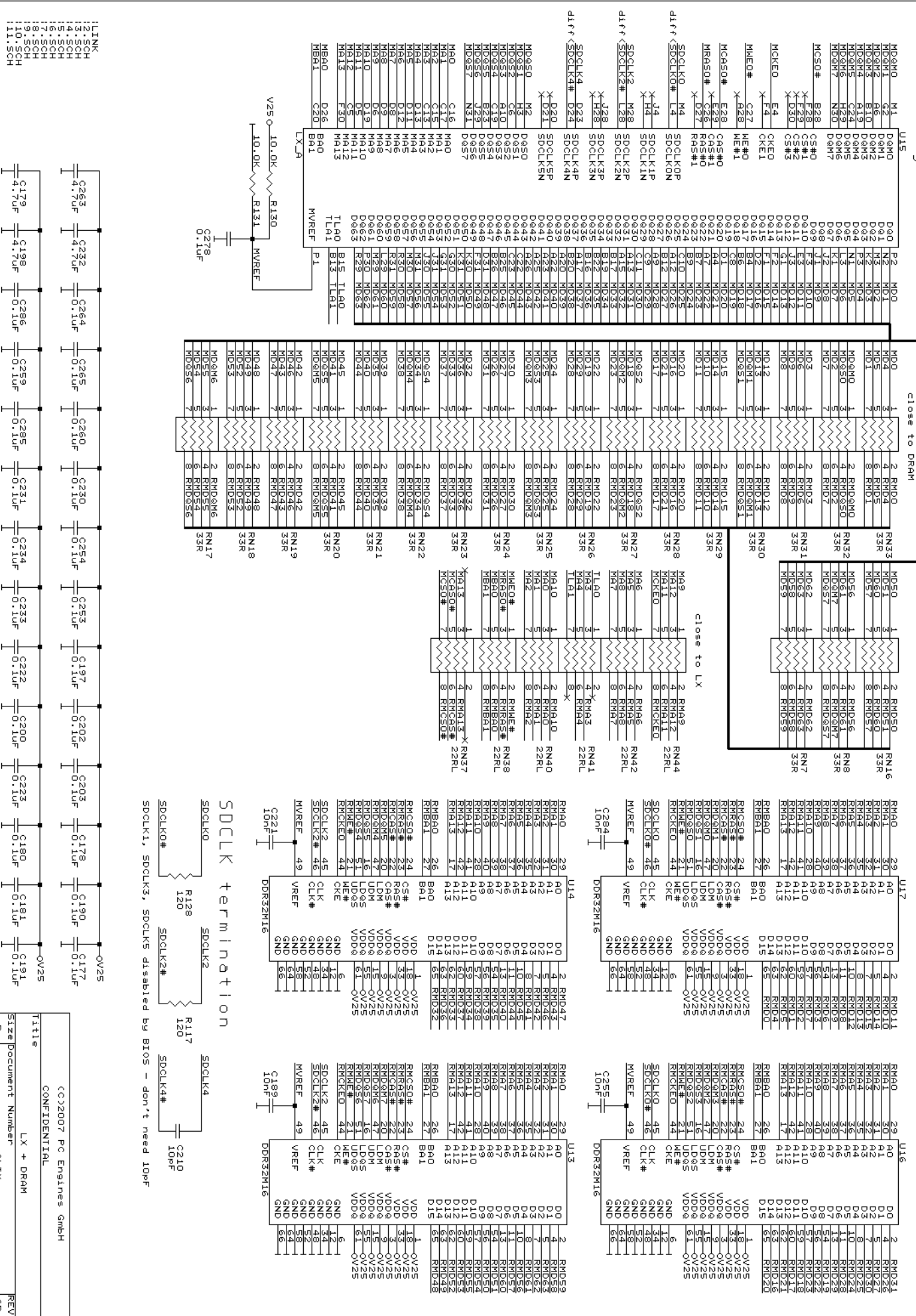

SDCLK1, SDCLK3, SDCLK5 disabled by BIOS - don't need 10pF

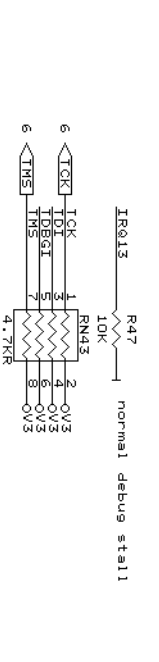
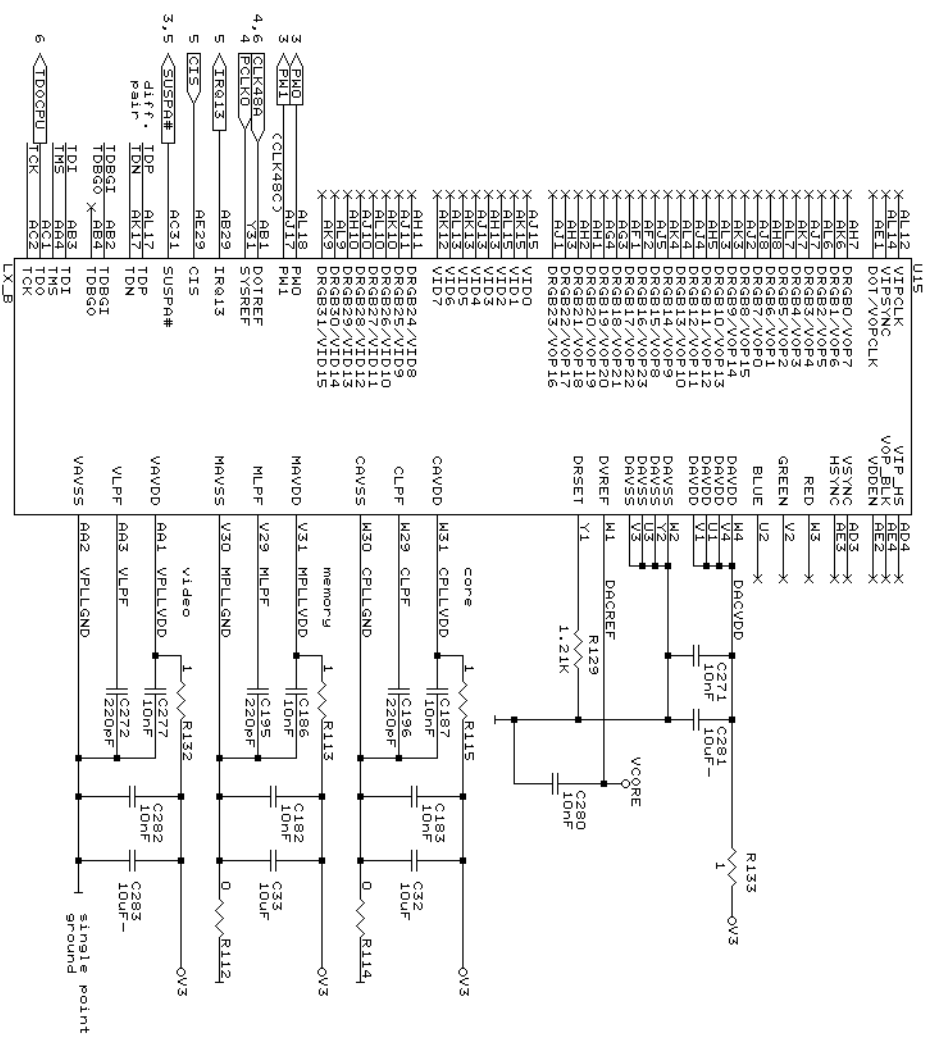

Thermal sensor

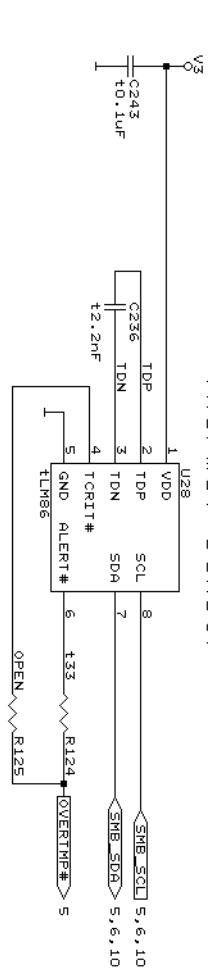

MiniPCI 1

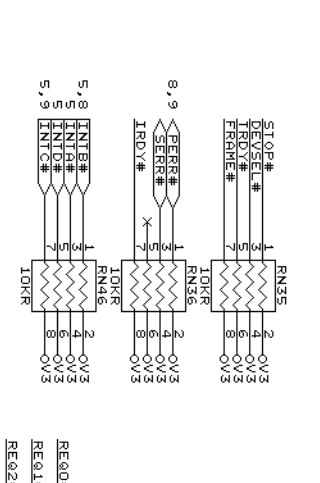
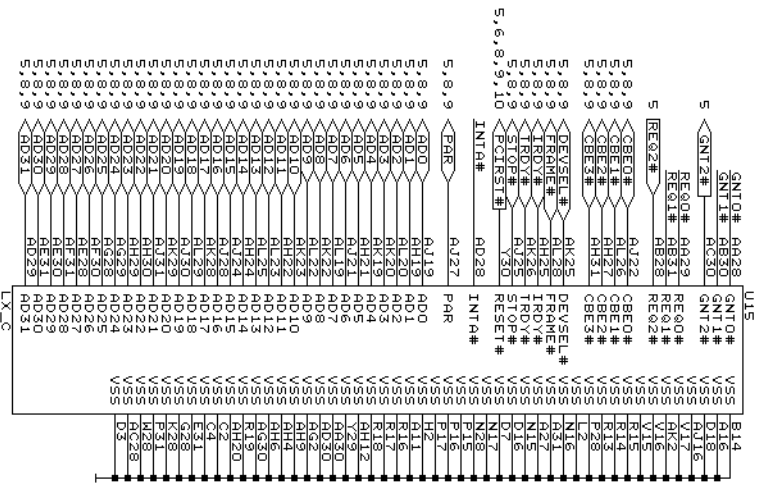

core / DRAM clock config

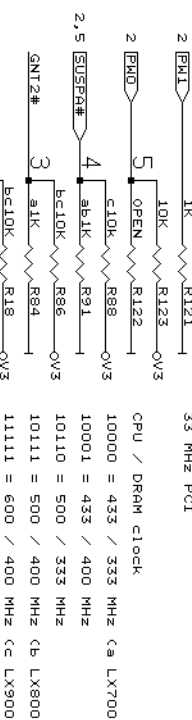

PCI arbiter

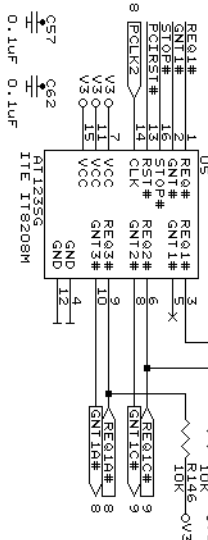



3, 8, 9	CEBQ#	U14	CEBQ#	U10
3, 8, 9	CEB2#	T9	CEB2#	
3, 8, 9	CEB3#	R6	CEB3#	
3, 8, 9	DEVSEL#	U9	DEVSEL#	
3, 8, 9	TRDY#	R10	TRDY#	
3, 8, 9	TRDY#	T10	TRDY#	
3, 8, 9	STOP#	A6	STOP#	
3, 6, 8, 9, 10	POIRST#	R2	RESET#	
3	ENTR#	R2	GO	
3, 8, 9	PAR	U10	PAR	
3, 8, 9	AD0	R17	AD0	
3, 8, 9	AD1	R16	AD1	
3, 8, 9	AD2	R16	AD2	
3, 8, 9	AD3	L16	AD3	
3, 8, 9	AD4	R15	AD4	
3, 8, 9	AD5	R15	AD5	
3, 8, 9	AD6	R15	AD6	
3, 8, 9	AD7	R15	AD7	
3, 8, 9	AD8	U14	AD8	
3, 8, 9	AD9	U14	AD9	
3, 8, 9	AD10	T13	AD10	
3, 8, 9	AD11	R13	AD11	
3, 8, 9	AD12	R13	AD12	
3, 8, 9	AD13	U14	AD13	
3, 8, 9	AD14	R12	AD14	
3, 8, 9	AD15	U9	AD15	
3, 8, 9	AD16	R12	AD16	
3, 8, 9	AD17	T8	AD17	
3, 8, 9	AD18	R9	AD18	
3, 8, 9	AD19	R9	AD19	
3, 8, 9	AD20	R7	AD20	
3, 8, 9	AD21	R6	AD21	
3, 8, 9	AD22	U6	AD22	
3, 8, 9	AD23	U6	AD23	
3, 8, 9	AD24	T6	AD24	
3, 8, 9	AD25	R5	AD25	
3, 8, 9	AD26	T4	AD26	
3, 8, 9	AD27	R4	AD27	
3, 8, 9	AD28	U3	AD28	
3, 8, 9	AD29	U3	AD29	
3, 8, 9	AD30	U1	AD30	
3, 8, 9	AD31	U1	AD31	
3	ENT2#	R1	ENT#	
3	REG2#	R1	REG#	
4	ECLK1	U4	PCLK	

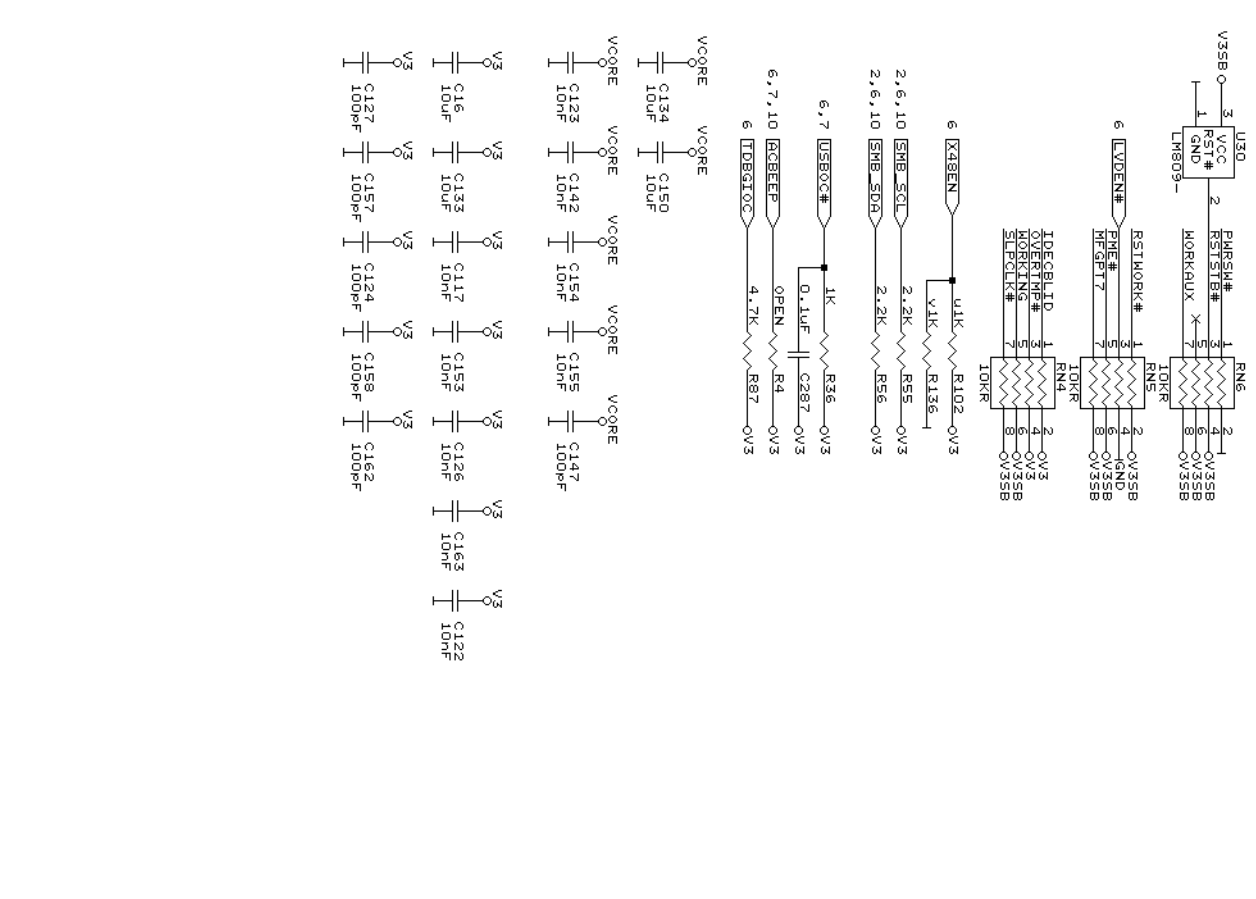
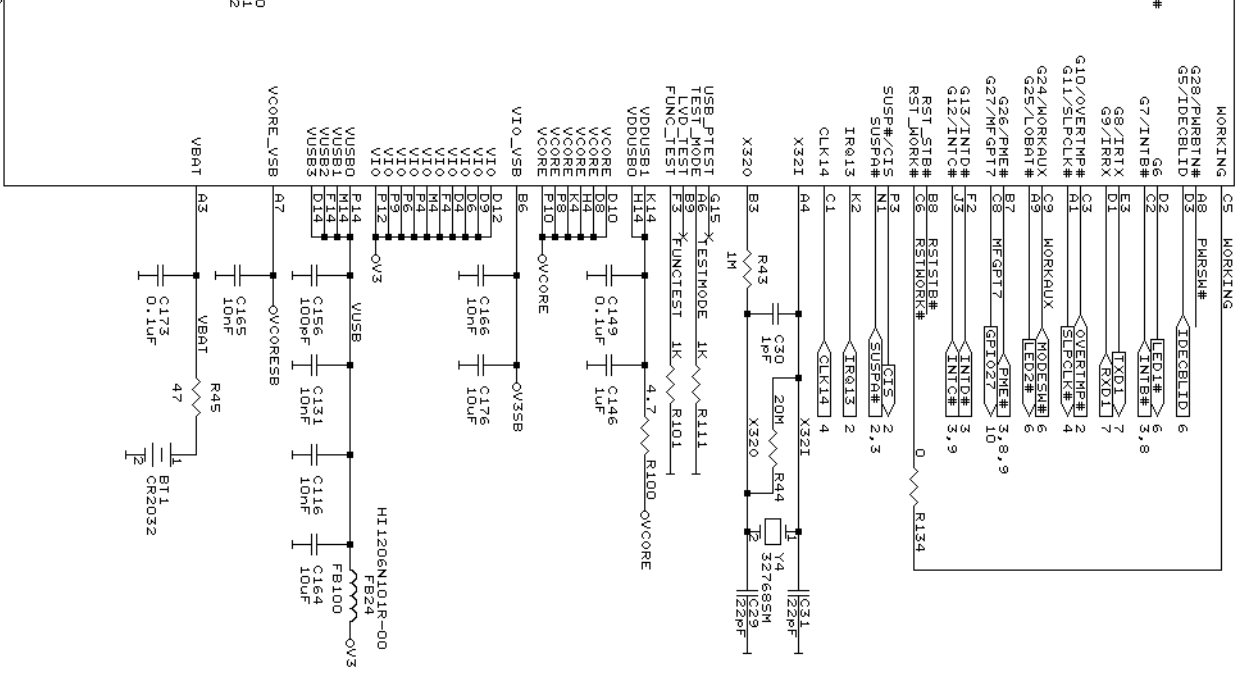

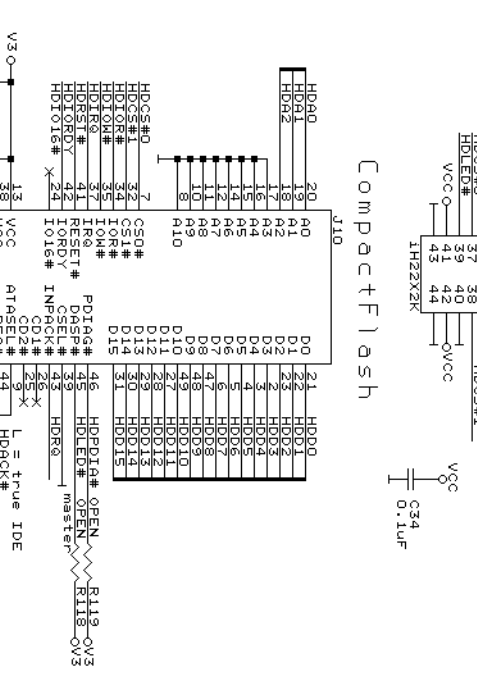
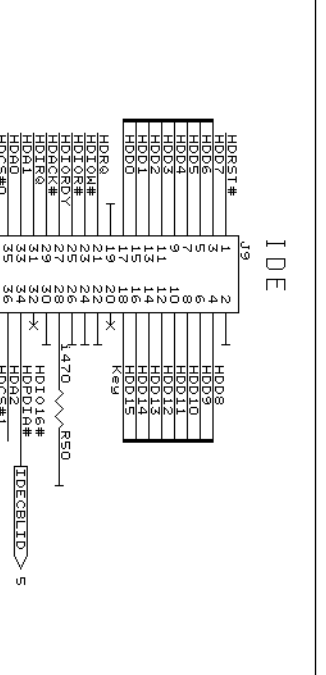
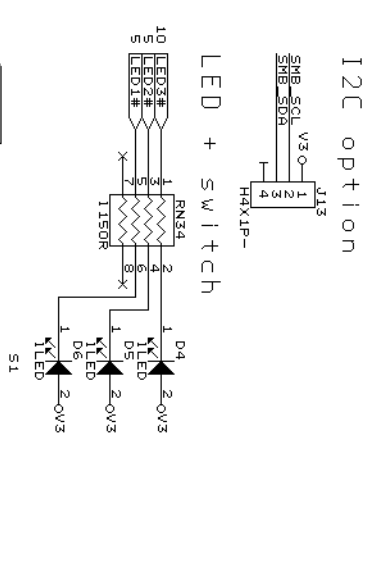
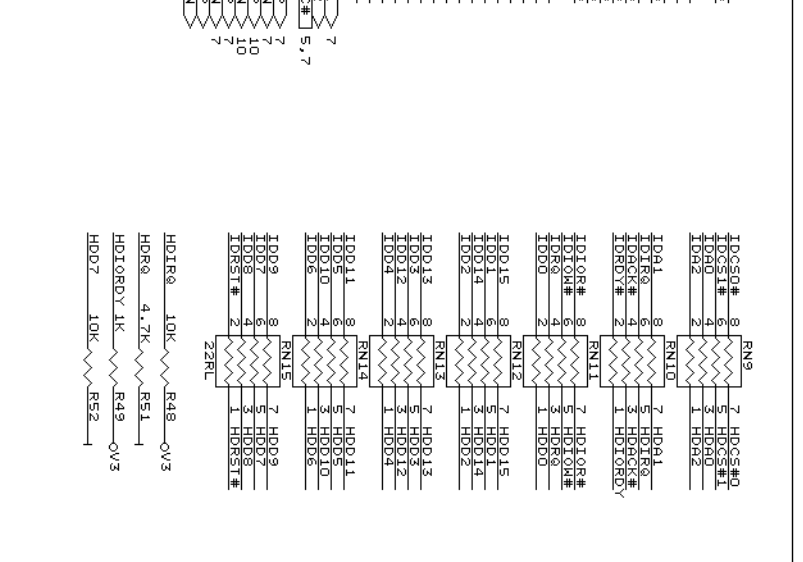
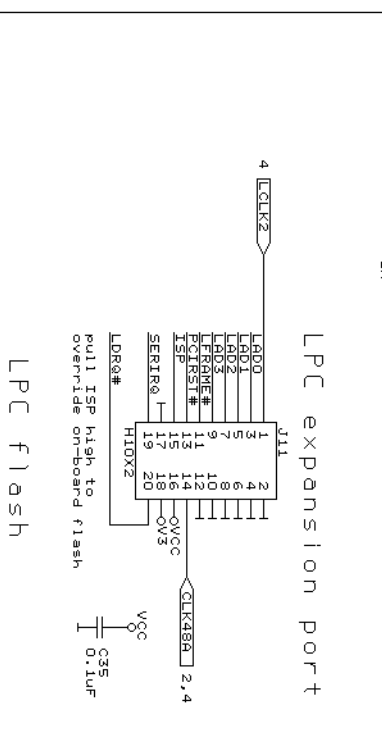
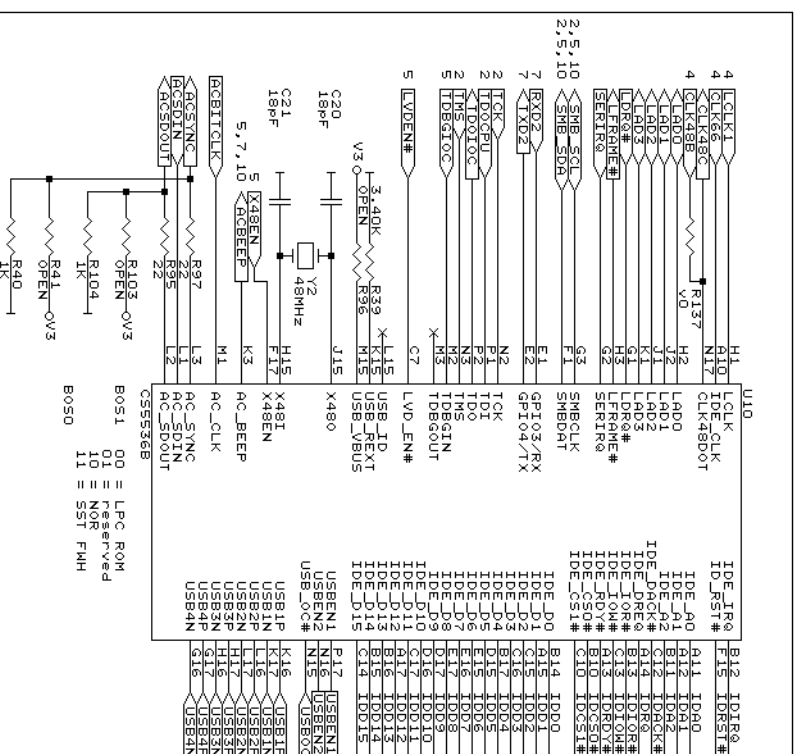

**LPC expansion port**

**LPC flash**

**I2C option**

**LED + switch**

**IDE**

**Compact flash**

U39

GPIO 14 OV3  
system board 1  
ID = 1

GPIO1 13  
GPIO2 14  
GPIO3 15  
GPIO4 16  
GPIO5 17  
GPIO6 18  
GPIO7 19  
GPIO8 20  
GPIO9 21  
GPIO10 22  
GPIO11 23  
GPIO12 24  
GPIO13 25  
GPIO14 26

GPIO 14 OV3  
system board 1  
ID = 1

GPIO1 13  
GPIO2 14  
GPIO3 15  
GPIO4 16  
GPIO5 17  
GPIO6 18  
GPIO7 19  
GPIO8 20  
GPIO9 21  
GPIO10 22  
GPIO11 23  
GPIO12 24  
GPIO13 25  
GPIO14 26

GPIO 14 OV3  
system board 1  
ID = 1

GPIO1 13  
GPIO2 14  
GPIO3 15  
GPIO4 16  
GPIO5 17  
GPIO6 18  
GPIO7 19  
GPIO8 20  
GPIO9 21  
GPIO10 22  
GPIO11 23  
GPIO12 24  
GPIO13 25  
GPIO14 26

GPIO 14 OV3  
system board 1  
ID = 1

GPIO1 13  
GPIO2 14  
GPIO3 15  
GPIO4 16  
GPIO5 17  
GPIO6 18  
GPIO7 19  
GPIO8 20  
GPIO9 21  
GPIO10 22  
GPIO11 23  
GPIO12 24  
GPIO13 25  
GPIO14 26

GPIO 14 OV3  
system board 1  
ID = 1

GPIO1 13  
GPIO2 14  
GPIO3 15  
GPIO4 16  
GPIO5 17  
GPIO6 18  
GPIO7 19  
GPIO8 20  
GPIO9 21  
GPIO10 22  
GPIO11 23  
GPIO12 24  
GPIO13 25  
GPIO14 26

GPIO 14 OV3  
system board 1  
ID = 1

GPIO1 13  
GPIO2 14  
GPIO3 15  
GPIO4 16  
GPIO5 17  
GPIO6 18  
GPIO7 19  
GPIO8 20  
GPIO9 21  
GPIO10 22  
GPIO11 23  
GPIO12 24  
GPIO13 25  
GPIO14 26

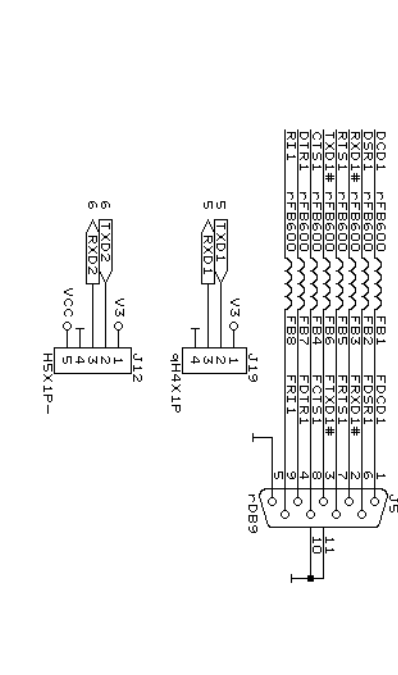
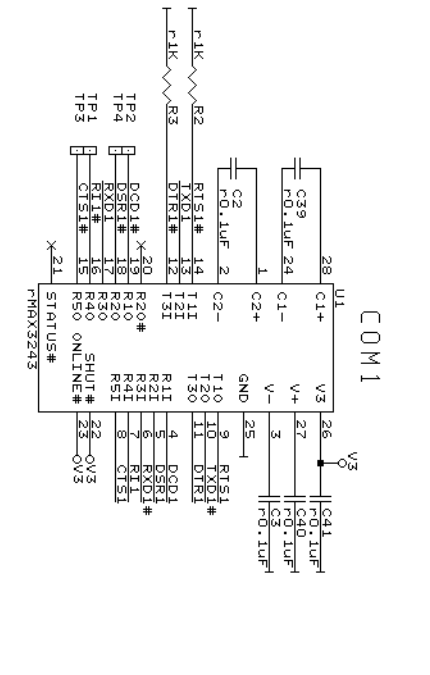
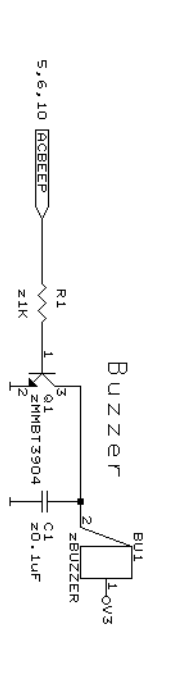
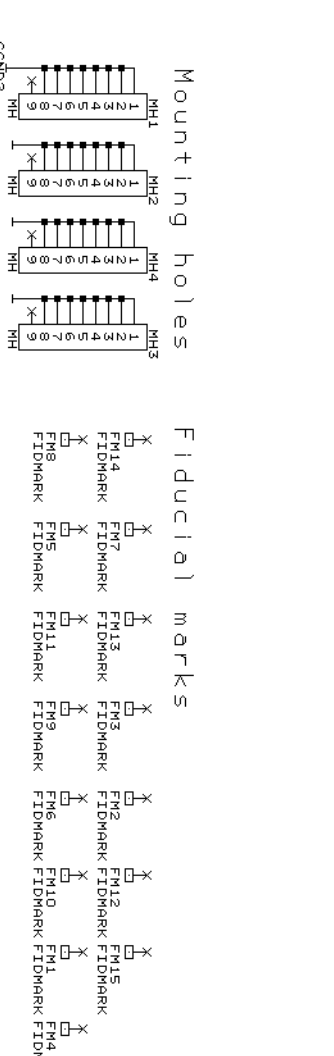
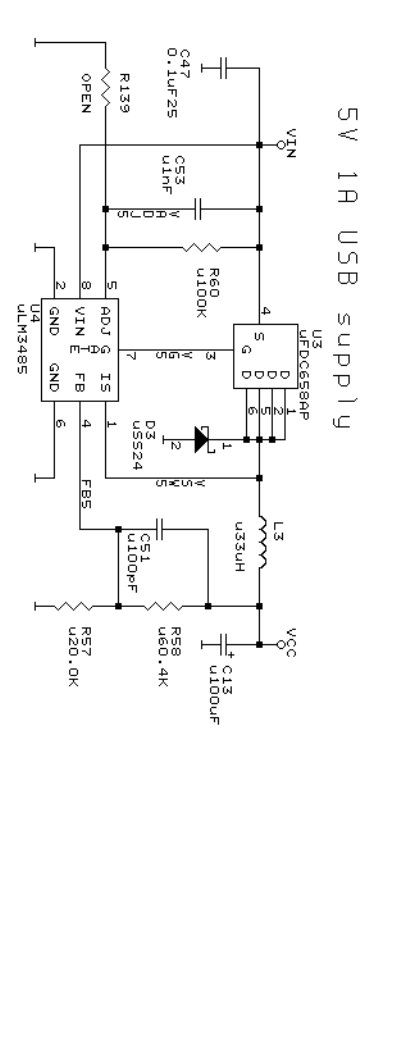
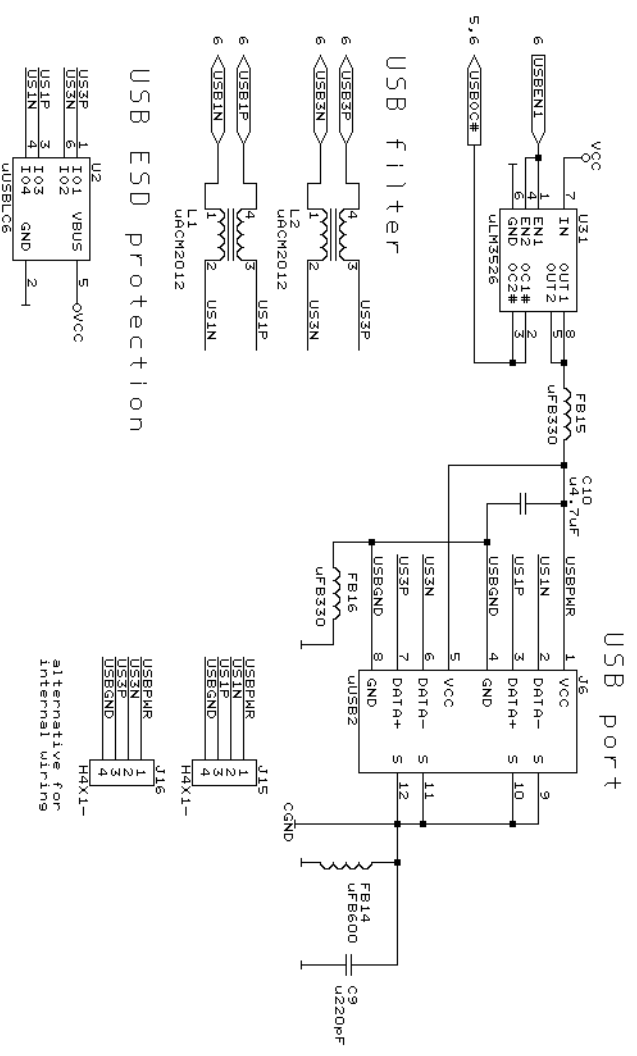

CC2007 PC Engines GmbH	
CONFIDENTIAL	
Title USB, front panel	
Size Document Number	ALIX
Date:	March 18, 2008 Sheet 7 of 11
REV	68

# VT6106H LAN 1

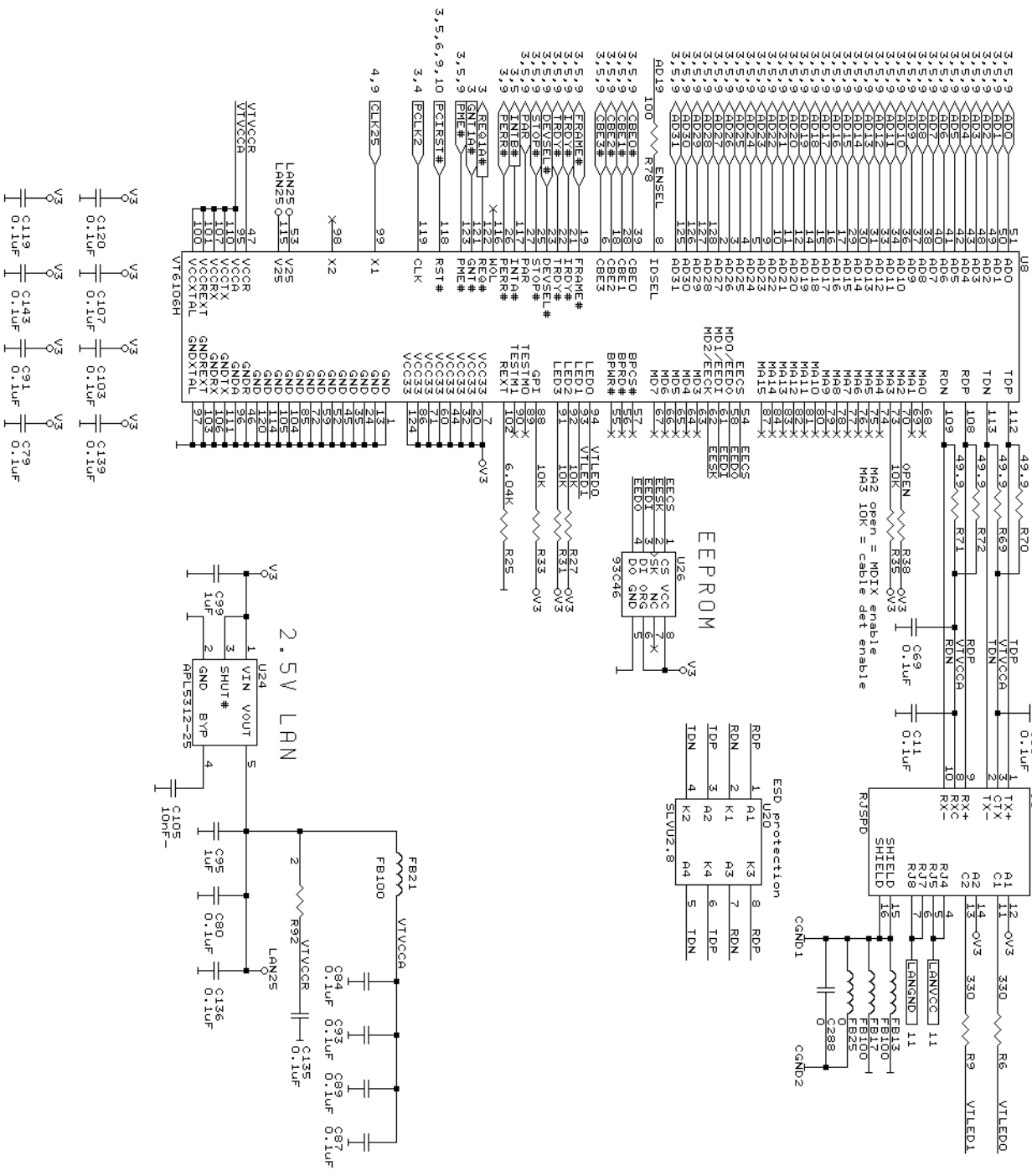

## 2.5V LDO

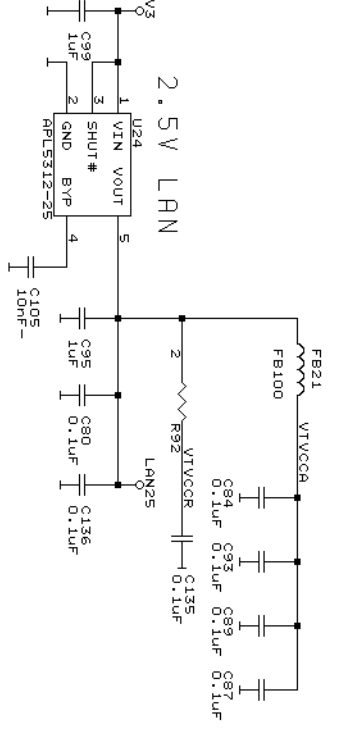

## EEPROM

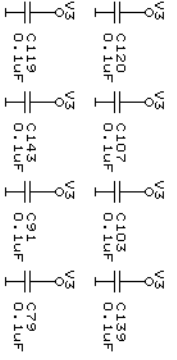
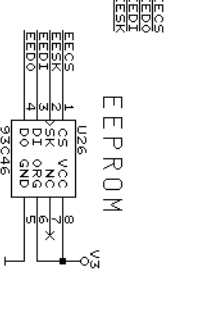



VT6106H LAN 2

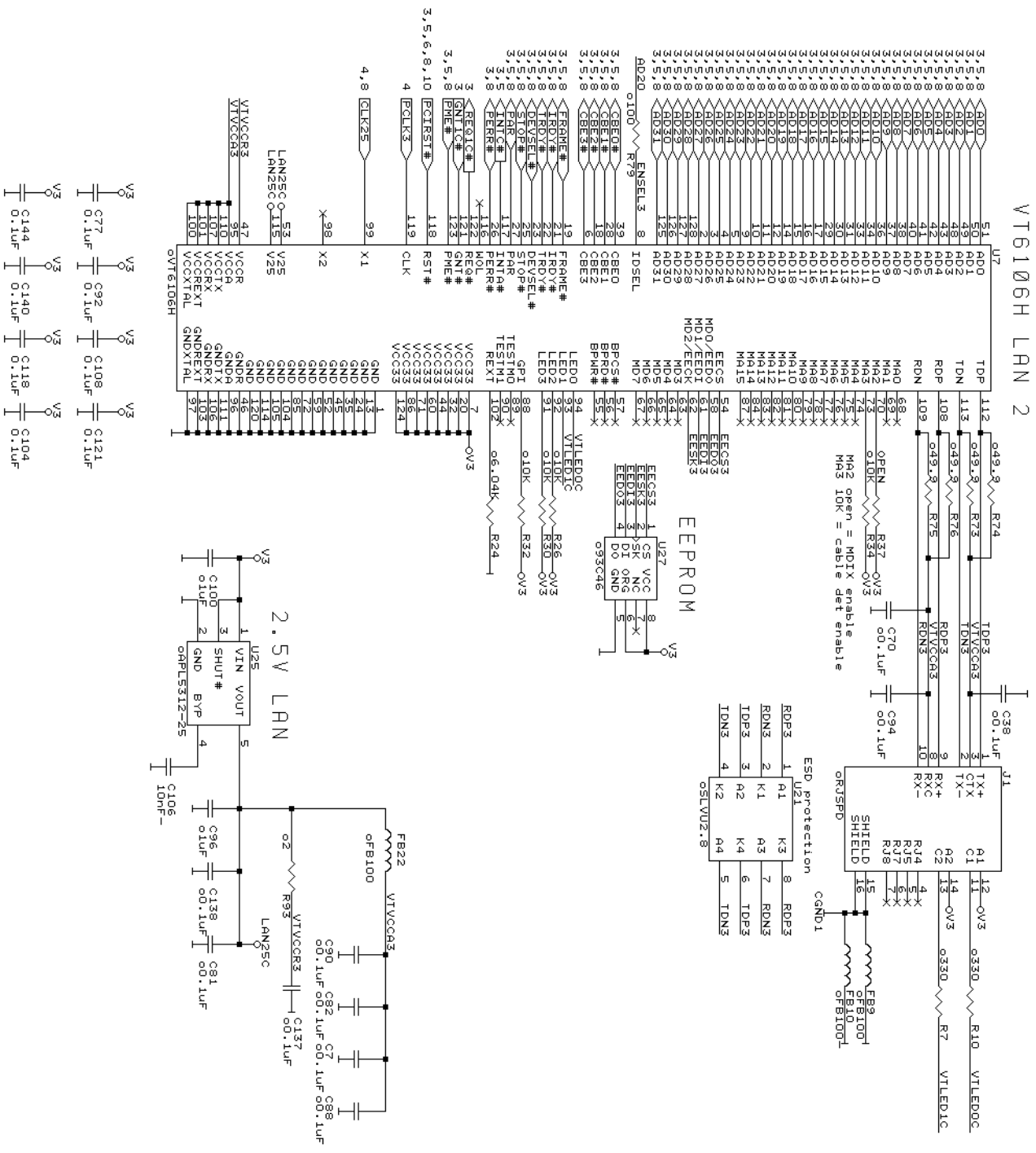

# MiniPCI Express

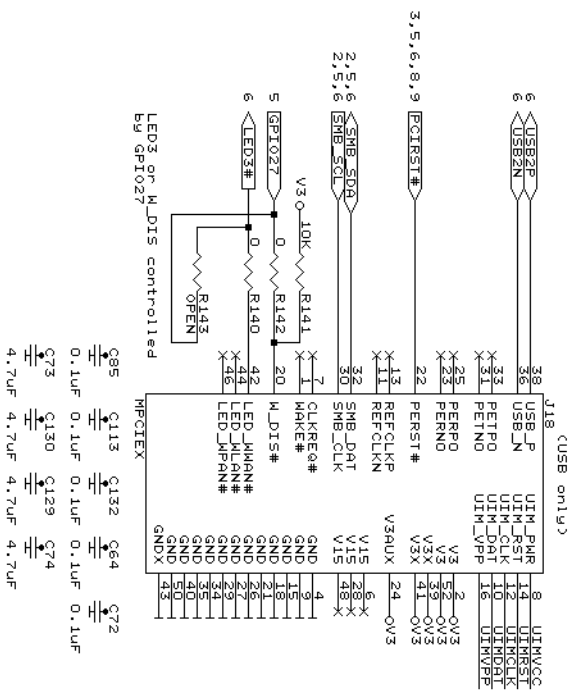

# USB ESD protection

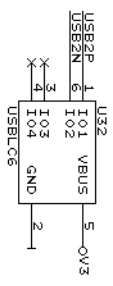

# SIM switch

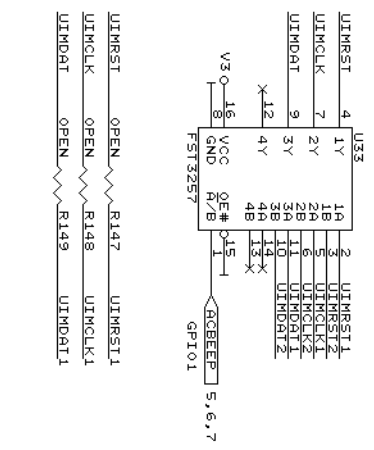

# primary SIM

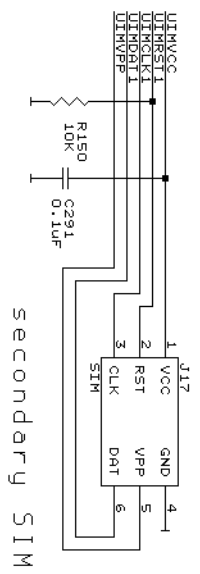

# secondary SIM

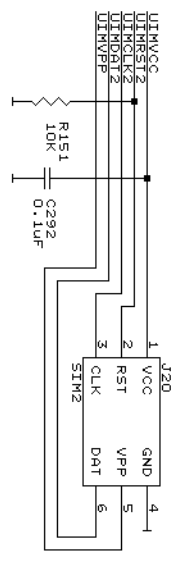

Power input +7..20V

5V bias

(also see alternative on sheet 7)

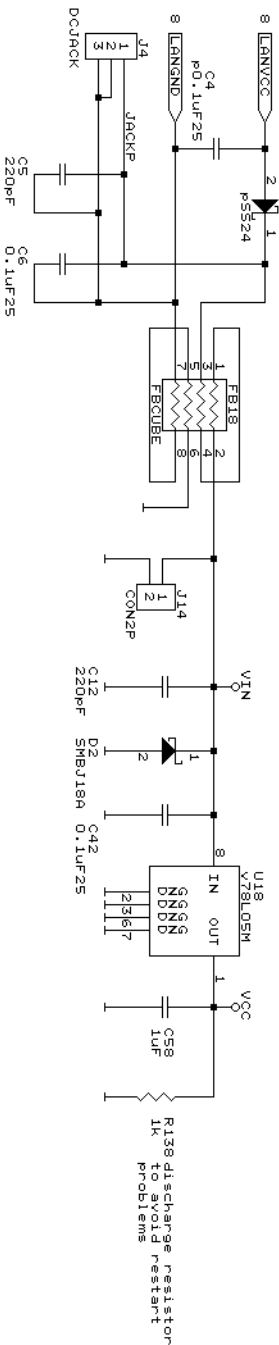

VCORE, V3 regulator

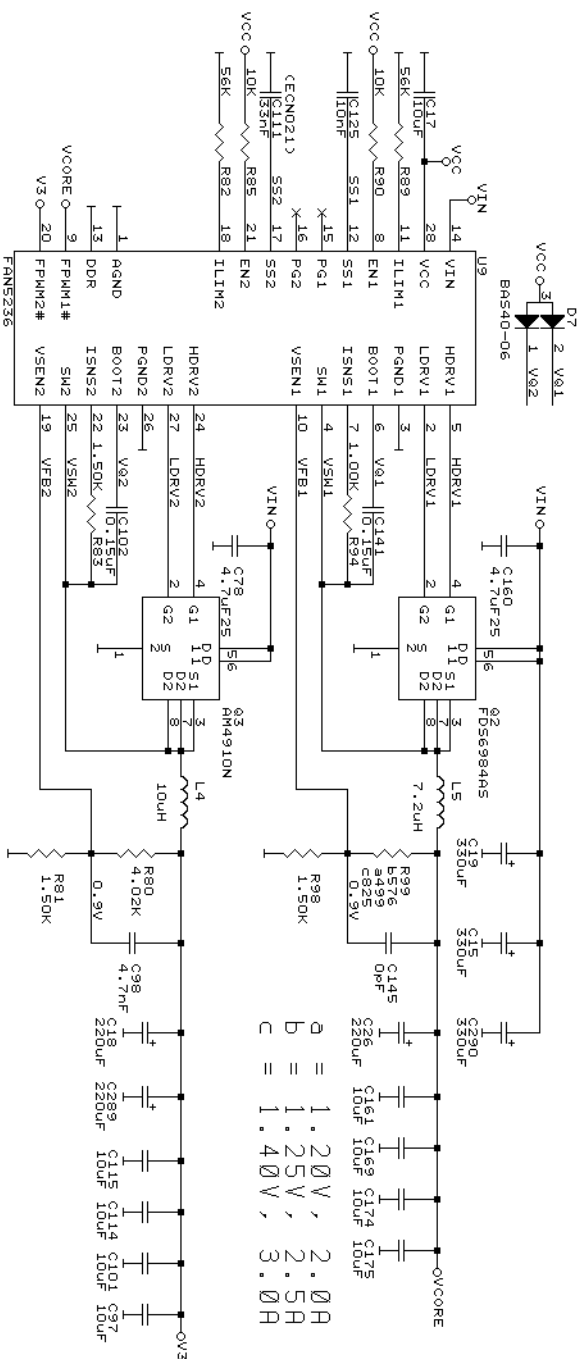

2.6V DDR supply

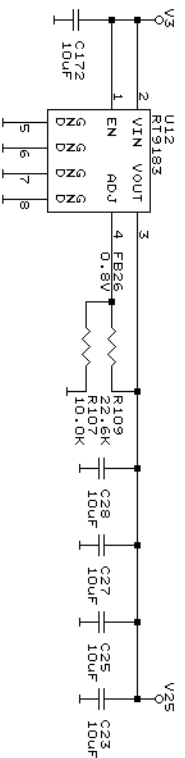

3.3V standby



1.2V standby

